

Installation Guide

Cabinet Surface Mount for Single Display

The purpose of this guide is to:

1. Describe the procedure for attaching Channel to cabinet top.
2. Describe the procedure for mounting the Column in the channel.



Parts Reference

The following parts and hardware are included with this installation kit (hardware not shown).

Item #	Description	Qty
1	Dual Channel Column, 18"	1
2	Cover Plate	1
3	1/4-20 x 5/8" Flat Head Socket Cap Screw (FHSCS)	4
4	Channel, 13" Seismic	1
5	Backing Plate, 13"	1
6	#10-32 x 1-1/4" Flat Head Machine Screw (FHMS)	6
7	#10-32 x 1-1/4" Pan Head Machine Screw (PHMS)	3
8	#10-32 x 1-1/2" FHMS	6
9	#10-32 x 1-1/2" PHMS	3
10	M-Series Flush Mount for Flat Panel Display	1
11	Display Mounting Kit (includes instructions)	1
12	Spacer, M8031B 15" Display	1
13	Spacer, M8033C 17" Display	1
14	1/8" Hex Wrench	1
15	5/32" Hex Wrench	1
16	Channel Cover, 16" L x 2" W	2
	Channel Cover, 12" L x 1" W	2

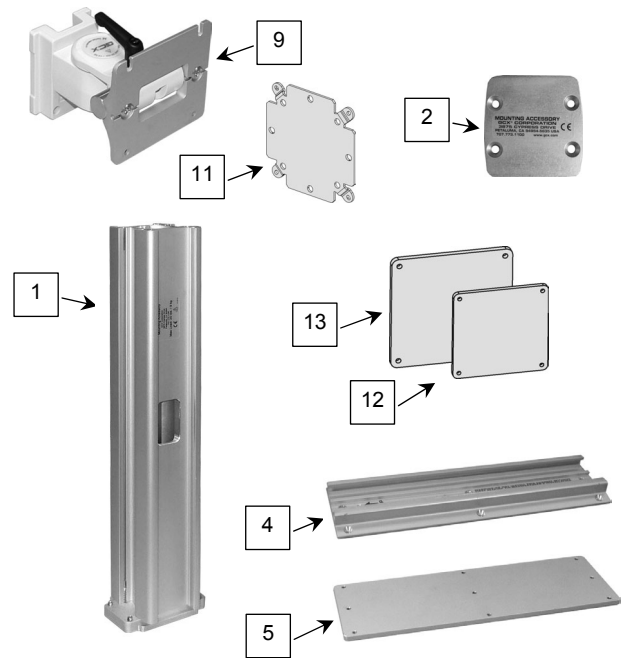

Tools Required

- Drill (not provided)
- 5/16" drill bit (not provided)
- Phillips screwdriver (not provided)
- 1/8" hex wrench (provided)
- 5/32" hex wrench (provided).



WARNING! It shall be the responsibility of the installer to determine whether the horizontal channel will support the weight of the Dual Channel Column and any mounted instruments or accessories. Load capacity decreases as the load is extended laterally from the Mount. This Dual Channel Column is not compatible with most anesthesia machine top plate applications.

Installing Horizontal Channel on Cabinet Top

Installation Note: Hardware is provided for attaching Channel to material from **3/4" [18mm] to 1" [25mm]** thick.

1. Using the Channel as a template, drill nine (9) holes through the cabinet top with a 5/16" drill bit.
2. Select required length of screw (1-1/4" or 1-1/2"), and fasten Channel to Backing Plate (through cabinet top) with six (6) #10-32 FHMS (outer holes) and three (3) #10-32 PHMS (center holes).

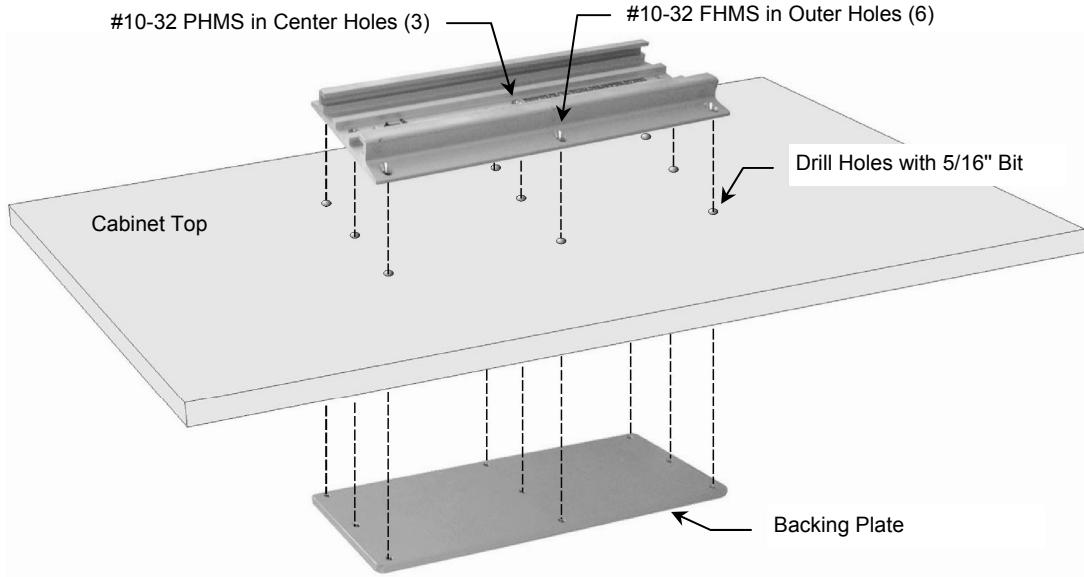

Mounting the Dual Channel Column in the Channel

1. Guide Channel Slide (bottom of Column) into Channel and move to desired mounting position.
2. Using the 1/8" hex wrench provided, tighten four (4) socket set screws to secure Column in Channel.



Mounting the Display Mount on the Column

1. Insert the Channel Slide in top of Channel and slide Flush Mount to desired mounting position. Using the 1/8" hex wrench provided, tighten two (2) set screws at bottom of Slide.

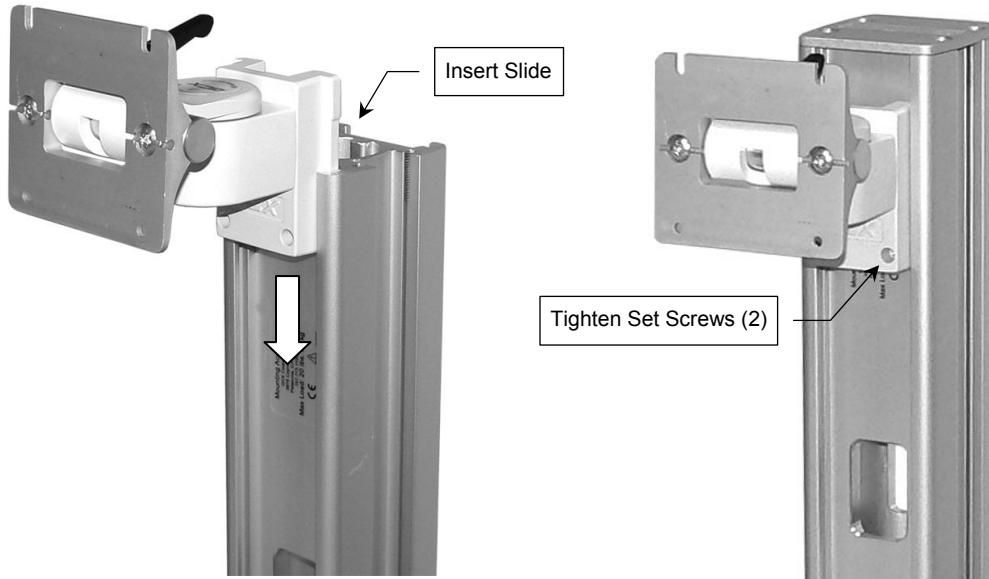

2. Using the 5/32" hex wrench provided, fasten Cover Plate to top of Dual Channel Column with four (4) 1/4-20 x 5/8" FHSCS (below). **Installation Note:** This step should be accomplished only after all devices and accessories have been mounted in the front and rear channels.

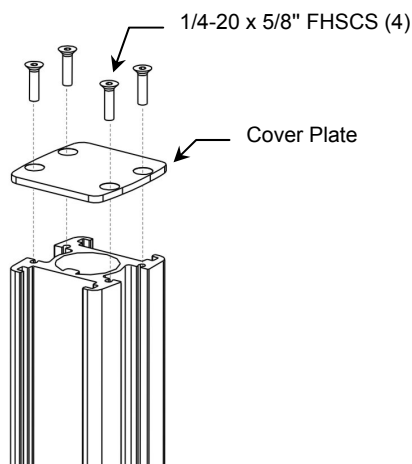

Mounting the Display

Mount the display using hardware from the *Mounting Kit for 75/100 VESA Compatible Flat Panel Displays (provided)*. This installation kit includes a detailed installation guide for mounting the display.

Installation Note: A Spacer (provided) is required for mounting either an M8031B (15") or M8033C (17") display. Insert appropriate Spacer and mount display as shown below. **15" display:** Use M4 pan head machine screws from *Mounting Kit for 75/100 VESA Compatible Flat Panel Displays*. **17" display:** Use M4 pan head machine screws plus VESA Mounting Adapter from *Mounting Kit for 75/100 VESA Compatible Flat Panel Displays*.

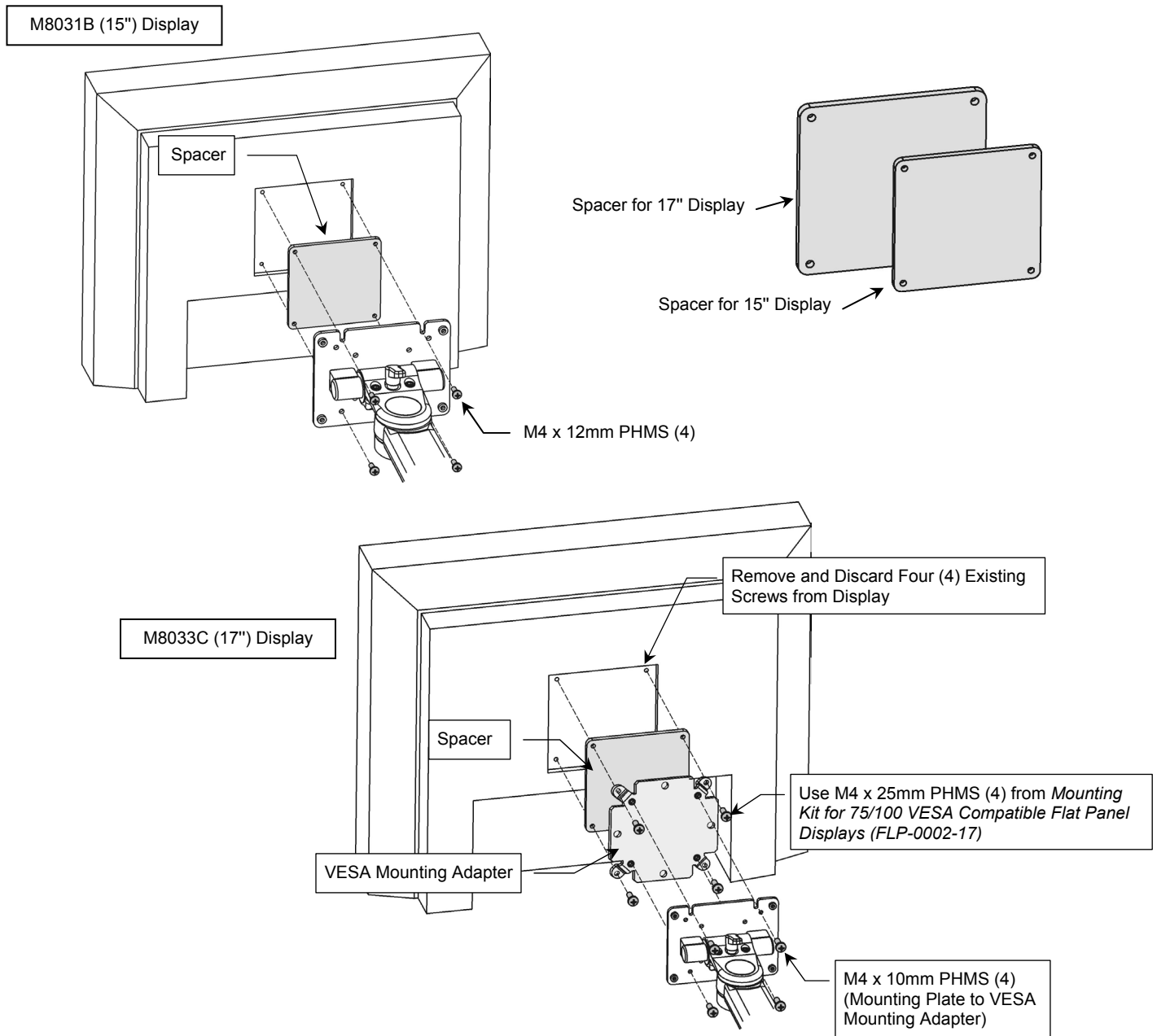

Cable Management

1. Cables may be routed through the rear of the Channel Slide.
2. A pass-through is provided in mid-channel to allow cables to be routed to the rear of the Column.
3. Channel Covers (not shown) are provided for both the 2-inch and 1-inch wide Channels. Channel Covers serve both as an aesthetic cover and may be used for cable management along the Channel. After all equipment has been mounted, install Channel Covers in accordance with separate installation guide.



Tilt and Swivel Adjustments

Tilt Position

Loosen Tilt Adjustment Lever. Grasp top and/or bottom of instrument and tilt to desired angle. Tighten Tilt Adjustment Lever.

Tilt Tension

Using the 5/32" hex wrench provided, equally tighten or loosen the two (2) Tilt Tension Screws achieve desired resistance.

Swivel Tension

Using a 1/2" socket wrench, loosen or tighten the swivel tension bolt on the bottom of the Swivel Head.

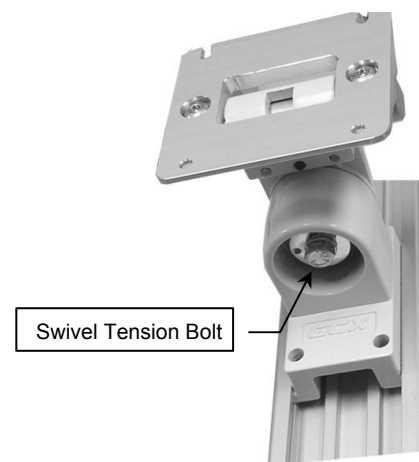
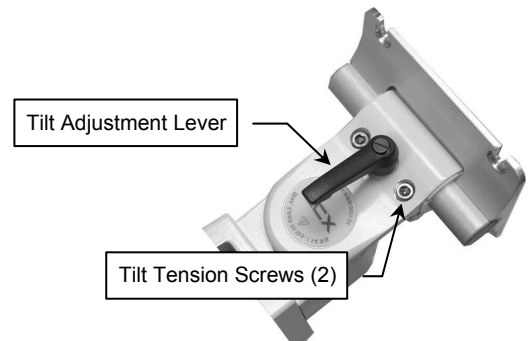

Routine Maintenance of the Mounting Assembly

Periodically check all mounting hardware. Tighten as necessary for optimal operation.

Cleaning the Mounting Assembly

CAUTION: GCX makes no claims regarding the efficacy of the listed chemicals or processes as a means for controlling infection. Consult your hospital's infection control officer or epidemiologist. To clean or sterilize mounted instruments or accessory equipment, refer to the specific instructions delivered with those products.

1. The mounting assembly may be cleaned with most mild, non-abrasive solutions commonly used in the hospital environment (e.g. diluted bleach, ammonia, or alcohol solutions).
2. The surface finish will be permanently damaged by strong chemicals and solvents such as acetone and trichloroethylene.
3. Do not use steel wool or other abrasive material to clean the mounting assembly.
4. Damage caused by the use of unapproved substances or processes will not be covered by warranty. We recommend testing of any cleaning solution on a small area of the arm that is not visible to verify compatibility.
5. Never submerge or allow liquids to enter the mounting assembly. Wipe any cleaning agents off the mounting assembly immediately using a water-dampened cloth. Dry all parts thoroughly after cleaning.