

## Installation Guide

### M-Series 8" x 8" Articulating Arm for Mounting Philips FMS on Left Side of Dräger Fabius GS Anesthesia Machine

The purpose of this guide is to describe installation of mounting assembly on the anesthesia machine.



**WARNING:** USE OF MOUNTING HARDWARE AND MONITORING COMPONENTS OTHER THAN THOSE DESCRIBED IN THIS DOCUMENT MAY RESULT IN SERIOUS INJURY DUE TO TIPPING OF THE ANESTHESIA MACHINE.

**WARNING:** ALL DEVICES AND MOUNTING EQUIPMENT SHOULD BE POSITIONED INWARD, CLOSE TO THE ANESTHESIA MACHINE, DURING TRANSPORT.

**Installer:** When installation is completed, provide these instructions and all related documentation to the end user for future reference.

### Parts Reference

The following parts and hardware are included in this installation kit (hardware not shown):

| Item # | Description                                | Qty |
|--------|--|-----|
| 1      | 8" x 8" Articulating M-Series Arm          | 1   |
| 2      | Down Post, 6"                              | 1   |
| 3      | #10-32 x 3/8" Socket Head Cap Screw (SHCS) | 3   |
| 4      | 1/8" Hex Wrench                            | 1   |
| 5      | 5/32" Hex Wrench                           | 1   |



### Tools Required

- 5/32" hex wrench (provided)
- 1/8" hex wrench (provided)

### Mounting Articulating Arm in Channel

1. Using the 5/32" hex wrench provided, fasten Post to Swivel Cup with three (3) #10-32 x 3/8" SHCS as shown below.

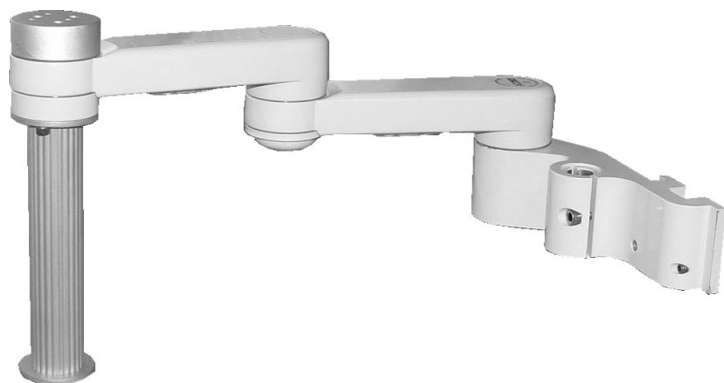
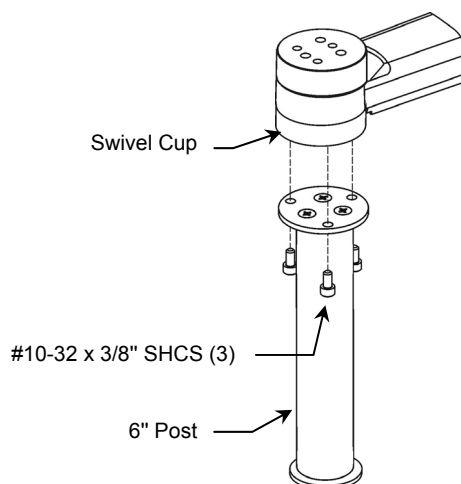

2. Insert Slide (rear of Arm) in opening in lower channel and move Arm to top of channel as shown below. Using the 1/8" hex wrench provided, tighten two (2) socket set screws to secure position in channel.

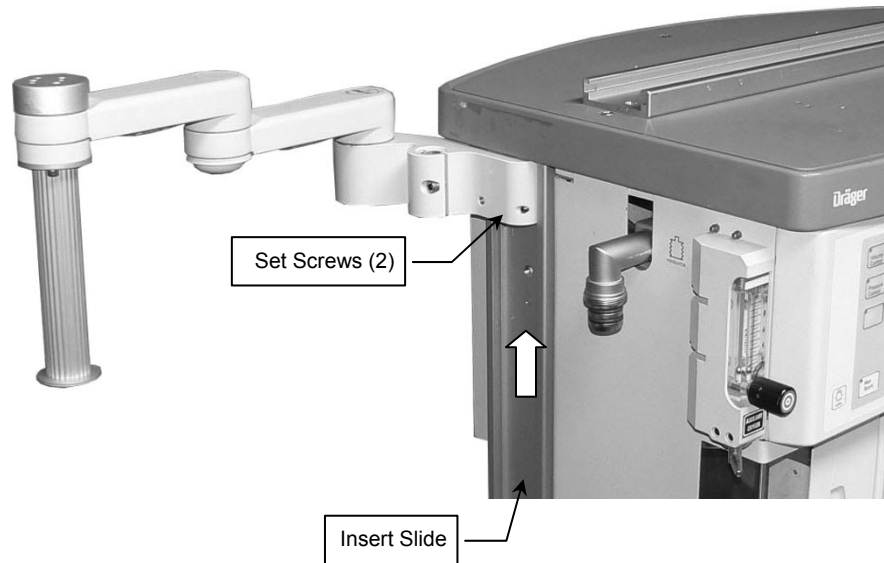

### Mounting FMS on Down Post

Follow Philips instructions for mounting FMS on Down Post. A Philips-supplied clamp is required for this installation.

**Installation Note:** The clamp on the rear of the FMS may be rotated 90° to allow vertical mounting of the FMS as shown below right.



## Periodic Maintenance

All fasteners associated with the mounting system should be inspected periodically and tightened or adjusted as necessary for optimal operation and safety.

## Cleaning the Mounting Assembly

**CAUTION:** GCX makes no claims regarding the efficacy of the listed chemicals or processes as a means for controlling infection. Consult your hospital's infection control officer or epidemiologist. To clean or sterilize mounted devices or accessory equipment, refer to the specific instructions delivered with those products.

1. The mounting assembly may be cleaned with most mild, non-abrasive solutions commonly used in the hospital environment (e.g. diluted bleach, ammonia, or alcohol solutions).
2. The surface finish will be permanently damaged by strong chemicals and solvents such as acetone or trichloroethylene.
3. Steel wool or other abrasive material should never be used.
4. Damage caused by the use of unapproved substances or processes will not be warranted. We recommend testing of any cleaning solution on a small area of the arm that is not visible to verify compatibility.
5. Never submerge or allow liquids to enter the arm. Wipe any cleaning agents off the arm immediately using a water-dampened cloth. Dry mounting assembly thoroughly after cleaning.